

## ZKLN0624-2RS-XL

Axial angular contact ball bearing

Schaeffler ID:  
0017102060000

Axial angular contact ball bearing  
ZKLN..-2RS-XL, double direction, no screw  
mounting

X-life

### Technical information

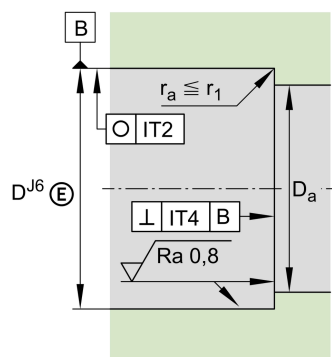
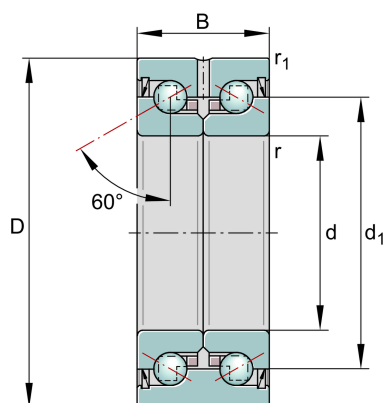

### Main Dimensions & Performance Data

d	6 mm	Bore diameter
	0.002 mm	Bore diameter upper tolerance
	-0.003 mm	Bore diameter lower tolerance
D	24 mm	Outside diameter
	0 mm	Outside diameter upper tolerance
	-0.01 mm	Outside diameter lower tolerance
B	15 mm	Width
	0 mm	Width upper tolerance
	-0.25 mm	Width lower tolerance
$C_a$	7,600 N	Basic dynamic load rating, axial
$C_{0a}$	8,500 N	Basic static load rating, axial
$C_{ua}$	520 N	Fatigue load limit, axial
$n_{G Grease}$	6,800 1/min	Limiting speed for grease lubrication
$M_R$	0.04 Nm	Bearing frictional torque
	37 g	Weight

